

**A MULTIPLE-CONSTRUCTS FRAMEWORK FOR
TEACHING CONTROL CONCEPTS**

Ilya Levin

David Mioduser

Tel-Aviv University
School of Education
Ramat-Aviv, 69978
e-mail: ilial@ccsg.tau.ic.il

Tel-Aviv University
School of Education
Ramat-Aviv, 69978
e-mail: miodu@ccsg.tau.ic.il

Final version published in:
IEEE Transactions on Education, 39(4), 1996 (pp. 1-9)
© by the publisher

Running head: MULTIPLE-CONSTRUCTS FRAMEWORK

Abstract

The phenomenon of control is an essential component of our everyday natural, social and artificial environment. Control-related concepts have become a central component of many core topics in modern technology education. However, our knowledge about the students' ability to understand (analysis) and design (synthesis) controlled systems is still poor. Evidence already collected shows that students have serious difficulties in transcending the phenomenal or behavioral understanding of a system's functioning, towards more formal definitions of the control process. In this paper a framework to start dealing with these and related issues is proposed. First, the nature of controlled systems is discussed. Then a conceptual framework encompassing a variety of perspectives on and approaches to control is presented. The framework consists of two main components: the process component and the representational component. The first relates to the stages in the process of defining and implementing control. The second is the repertoire of constructs used for defining and implementing control. Two main paradigms are suggested as the conveyors of very different cognitive approaches to control: programming and design paradigms. Finally the educational implications of the proposed framework at both the cognitive and the instructional levels are discussed.

A MULTIPLE-CONSTRUCTS FRAMEWORK FOR TEACHING CONTROL CONCEPTS

Introduction

The phenomenon of control is an essential component of our everyday natural, social and artificial environment [1] - [2], and control-related concepts have become a central component of many core topics in modern technology education [3] - [4] - [5]. Computers, programmable controllers, CNC, CAM, dynamic systems and other important subjects of the technology curriculum are based on the general idea of control.

However, our knowledge about the students' ability to understand (analysis) and design (synthesis) controlled systems is still poor. Evidence already collected [6] - [7] - [8] - [9] shows that students have serious difficulties in transcending the phenomenal or behavioral understanding of a system's functioning, towards more formal definitions of the control process. For example, Ackerman's [8] subjects think in terms of transactions among elements, where element "a" does something (or tells to do something) to "b". The actors ("a" and "b") are being alternatively animated according to "who" impacts (or is impacted by) "whom". Mioduser et al.'s [9] subjects related controlling functions to particular physical components (e.g., sensors, motors), assumed as responsible for making the decisions governing the system's behavior. Most students were able to identify control functions, but only part of them were able to formally define the control specifications and procedures.

Two additional aspects further complicate the picture. The first is related to prerequisite knowledge. Dealing with controlled systems means in the first place

dealing with systems in general, the control component being a subsystem of the whole system. Concepts like system, information flow within the system, and feedback (among many others) are the necessary background for studying the more particular topic of control. Although we are aware of the need for this prerequisite knowledge, we will focus in this paper on the specific issues of controlled systems.

The second source for potential difficulties relates to the variety of perspectives in conceiving control. For example, we may think of the engineer's view of a controller as a collection of logical components designed to transform inputs into outputs, as opposed to the programmer's view of control as the running of a computer program that guides a device's performance. We will later refer to these and other alternative approaches as different control paradigms. We will also propose that the differences among the paradigms could be the source of different cognitive and instructional approaches for learning and teaching control.

Teaching control (analysis and design) concepts implies facing several key questions, such as:

- How is the concept of control conceived (or misconceived) by students at different age levels? How do these conceptions develop?
- What (mental) model of control will be appropriate to teach to students at different age levels seeking different learning goals (e.g., school age children acquiring technological literacy, technicians being trained to repair a device)?
- How do different paradigms for defining and representing control affect people's conceptions, both for analysis and design purposes?
- How do the interaction between the system's level of complexity and the paradigm used for defining its control affect people's conceptions?

- How should the instruction of control concepts be planned (e.g., content, learning environment, representational formalisms, computer implementation tools)?

In this paper we propose a framework to start dealing with these and related questions. First, we will briefly refer to the nature of controlled systems. Then we will propose a conceptual framework encompassing a variety of perspectives on and approaches to control. Finally we will refer to the educational implications of the proposed framework, at both the cognitive and the instructional levels.

Controlled Systems

Several technological developments in the 1940's can be viewed as a turning point in the contemporary history of controlled systems. These developments made possible the building of electronic switching machines for executing calculations and stored programs, and of self-regulating computing devices. This nascent field of control and communication was named "cybernetics" by Wiener [10].

The most representative system of this (since then) rapidly growing field is the computer. The first computer systems were developed using electronic elements, assembled for performing certain functions. The first problem to arise in the process of development of these systems was that of design. In other words, the problem was to find a method for creating any computer system. Such a method was developed. It is based on the principle of dividing the system into two main components: operating unit (OU) and control unit (CU). The operating unit contains performing elements (e.g., adders, counters, registers). The control unit implements the algorithm of the processing of information.

Figure 1 consists of a representation of the structure of a general controlled system. The set $X=\{x_1,\dots,x_L\}$ of binary signals, transferred from the OU to the CU can be named the world state of the system. The set of binary signals $Y=\{y_1,\dots,y_N\}$ sent by the CU to the OU is the set of microoperations affecting the OU's behavior. The goal of the CU is the generation of a sequence of signals Y, distributed in time. The functioning of the OU is dictated by this sequence.

Insert Figure 1 about here

Many examples of devices and systems that can be viewed as instances of the above presented structure are part of our immediate physical environment. An interesting example of such systems is nowadays being introduced into schools in the form of building and programming kits (e.g., the Lego-Logo kits). These kits allow the students to build physical devices by means of modular building bricks, and to write computer programs to control the functioning of these devices [11]. The brick structures can be defined as the operating units of the system, while the computer program can be viewed as the implementation of the system's control unit.

These building and programming kits offer a unique opportunity for teaching and learning control concepts. But for this potential to be realized their implementation should be supported both at the cognitive and the curricular levels. This involves the development of appropriate instructional materials and learning environments side by side with the systematic study of the learning process of control-related concepts and skills.

In the following we want to suggest a conceptual framework for dealing with the required cognitive and curricular effort: a multiple-constructs framework for control.

A Multiple-Constructs Framework for Control

This framework is intended to serve as reference for the design of the instruction, as well as for the formulation of key research questions and research plans. To clarify its presentation, we will use all along the example of a particular device built with the Lego bricks. This device will serve to illustrate the different control constructs and approaches in our model. The device (Figure 2) was equipped with two motors and a light sensor, and could be defined as a “line-seeker device”. It moves on a surface following a black line drawn on it. Whenever the line-seeker gets to one end of the line it makes a turn until it “finds” the line again, continues to follow it to the other end, and so on.

Insert Figure 2 about here

The proposed framework consists of two main components: the process component and the representational component. The first relates to the stages in the process of defining and implementing control. The second is the repertoire of constructs used for defining and implementing control. These two components are presented in the next two sections.

Process for Defining and Implementing Control

We propose a didactic sequence of three stages for describing and/or designing the control part of a system: its initial description or definition, its formal model, and its implementation.

We will call the preliminary and descriptive explanation of the behavior of the system the initial description of its control part. The question to be answered at this stage is “What is the observed or desired behavior of the system?” The expected answer will be a natural language description of that behavior.

At the next stage, we will look for an exact expression of the initial description, using a specific formal notation. The question to be answered here is “What is the exact (formal) description of the system's desired behavior?”, the answer constituting the formal model of the control part of the system.

Finally we will ask the question of “How will control be actually implemented?” The outcome of this stage will be a working version of the control module which provokes the device to perform the desired behavior.

Repertoire of Constructs for Defining and Implementing Control

The second component of our framework refers to the alternative constructs we may use for representing control at the three stages mentioned in the previous section. The control research and development field offers a rich repertoire of notation systems and means of implementation [12] - [13] - [14] - [15] - [16]. Some of these constructs are everyday working-tools for engineers, designers and programmers dealing with control-related tasks. However, for the study of the teaching and learning of control, we found it necessary to rearrange and reorganize the disciplinary knowledge and tools so as to respond to our curricular and cognitive concerns. In our

model we have chosen a particular set of constructs which we considered the more relevant for our purpose, and we arranged the constructs as shown in Figure 3.

Insert Figure 3 about here

As suggested in the previous section, at the initial description stage the outcome is a behavioral description of the system's functioning. For our example of the line-seeking device the behavioral description could be as follows:

The device should always look for the line. When it is on the right side of the line, it has to turn to the left, until reaching the line again. If it passes the line to its left side, the device has to turn to the right until reaching the line again. At the end of the line the device has to continue turning until it reaches the line again.

Given the behavioral description of the system's (observed or desired) functioning, from the formal model stage onwards we suggest the distinction between two main paradigms: the programming paradigm and the design paradigm. In this paper we will elaborate on the assumption that these two paradigms represent two clearly separate and distinguishable approaches for defining and implementing control. They imply different (mental) modeling of control phenomena, different methodologies and means, and even different academic and professional disciplines.

The Programming Paradigm. By the programming paradigm, the person (e.g., student, user, technician, designer) assumes the existence of a control performer (e.g., a microprocessor), in charge of running the control specifications. This kind of

CU can be defined as a programmable controller. By this paradigm, to create control means to create an appropriate program.

Within the programming paradigm, several approaches can be taken. Here we will describe two examples: the algorithmic and the functional approaches. Let us describe these approaches for the next two levels of the control design process, namely, the formal-model definition stage and the implementation stage.

The key formal construct for the algorithmic paradigm is the flowchart (Figure 4). A flowchart is a directed connected graph which includes an initial vertex, a final vertex and a finite set of operator and conditional vertices. The final, operator and conditional vertices have only one input, and the initial vertex has no input. Initial and operator vertices have only one output, and conditional vertices have two outputs marked as “1” and “0”. The final vertex has no outputs.

Defining characteristics for a flowchart are also the following:

(a) Output vertices are connected by arcs to input vertices. Every output is connected only to one input, every input is connected from at least one output. One of the outputs of a conditional vertex can be connected to its input forming a waiting vertex (since it simulates a waiting cycle in the system’s functioning).

(b) Every vertex is part of at least one path leading from the initial vertex to the final vertex.

(c) A logical condition from set X appears in each conditional vertex. A given logical condition may appear in different conditional vertices.

(d) A microinstruction or operator Y_i (a subset of the set of microoperations Y) appears in every operator vertex. A given operator may appear in different operator vertices.

The flowchart constructed for our example is shown in Figure 4. The motors will be activated depending on the sensor's input values (“ x_1 ” being either 0 or 1).

Insert Figure 4 about here

A common implementation of the algorithmic approach could be a program written in BASIC or similar programming languages.

The second approach is based on the concept of function. We may refer to the D-function calculus as the formal construct for the functional approach. The basic D-function definition is:

$$D_i = D_1 \# \dots \# D_j$$

meaning that D-function D_1 is performed before D-function D_j .

$$D_j = j_1 D_1 + \dots + j_K D_K + j_m Y_1 + \dots + j_M Y_M$$

where j_k is a boolean function of the input variables $X = \{x_1 \dots x_L\}$, and:

$$j_k D_k = \begin{cases} D_k, & \text{if } j_k=1 \\ 0, & \text{if } j_k=0 \end{cases}$$

At the implementation stage, we may use a functional programming language for implementing control. In such a language, all procedures are well-defined functions of their arguments [17]. The most popular example of a functional programming language in education is Logo. The D-functional description of the line-seeking device's control and the corresponding Logo program are shown in Figure 5.

Insert Figure 5 about here

The program example is written in TC-Logo, the version of the language used in the Lego-Logo building and programming kits. The main procedure (D1) runs the sequence of “D” procedures. D0 and D1 check the inputs and run the correspondent procedures for activating (Y1) or deactivating (Y0) the motors.

The Design Paradigm. By following the design paradigm, the person (e.g., student, user, technician, designer) focuses on the logical scheme inside the CU, implemented by means of logical elements of varied nature (e.g., logical gates, contacts, programmable logical devices). For the previous programming paradigm the CU was defined as a programmable controller. Now we will define it as designable controller. To create control means to design the configuration of elements most appropriate for generating the desired behavior.

A key idea within the design paradigm is that the system is conceived as a finite state machine. The CU can be characterized by its state and may perform different functions (i.e., changing to other states) with the same input, depending upon the current state. The formal construct we consider the more appropriate for the formal-model definition is the state diagram (Figure 6). The state diagram is a representation of the system's possible states and the transitions among them. The nodes in the graph indicate states (a_1, a_2, \dots, a_M), and the arrows the transitions between states according to the input values which would cause such transitions. Figure 6 shows the state diagram for our example, the line-seeking device. Also in the figure appears the state table, a tabular form of the state diagram. The columns in the table indicate the

current state, the alternative input values, the corresponding output, and the next stage.

Insert Figure 6 about here

Against this background, we may define control as the process by which the system's transition from one state to another occurs. That implies that the system could be, at one time, in any of a number of possible states; that there are conditions under which a change in state takes place; and that control implies choice.

Representing the system as a finite-state machine is usually called abstract synthesis. At this level of description we deal purely with input-output transformations, ignoring the structure of the control unit. At the next stage we also have to take into account the internal structure of the CU, that is, we have to create the structure of the CU. This stage of design is usually called structural synthesis. We will use here the most popular structure of CU - the canonical structure or sequential machine. The canonical structure of the control unit is shown in Figure 7.

Insert Figure 7 about here

According to the canonical structure the control unit consists of two components. The first is the combinational scheme (CS), containing the set of elementary elements (or building blocks). The second is the memory register (M), built out of two-states elements (e.g., flip-flops). The control unit receives as inputs incoming data from the operating unit (vector $X=\{x_1, \dots, x_L\}$) and the current state

(vector $T=\{T_1,\dots,T_R\}$) as stored in the memory register, thus generating its outputs (vector $Y=\{y_1,\dots,y_N\}$). The new state is then stored in the memory (vector $D=\{D_1,\dots,D_R\}$).

We may think of implementing the structure of the CS in several ways, e.g. logical gates, Programmable Read Only Memory structure (PROM). As an example we will refer to two alternative constructs: PROM structure and relay scheme.

Figure 8 shows the PROM implementation for the line-seeking device in our example. This kind of construct focuses on the logical configuration of the structure of the CU.

Insert Figure 8 about here

The structure comprises the PROM (combinational part) and three RS flip-flops. The PROM consists of a fixed AND array, and a programmable OR array [18].

Figure 9 illustrates the relay scheme implementing the control unit of our example. We adopted here a widely used representation, the ladder diagram [15].

A ring of a ladder diagram program is a graphical representation of a Boolean assignment statement. The dependent variable of the logical equation is represented by a circle. The independent variables (the ring inputs) are represented by pairs of small vertical parallel bars. A horizontal line between the bars indicates that the complementary value of the variable is used. The OR function is constructed by placing two or more variables in parallel. By these representational means, any Boolean equation can be formulated.

The ladder diagram description of the line-seeking device control is shown in Figure 9. This representation is equivalent to the previously presented PROM structure. Rings 1 to 10 of the ladder diagram implements a Boolean assignment statement, corresponding to “1” in the programmable OR array of the PROM (Figure 8). Rings 11 to 13 are implementations of the flip-flops RS1, RS2 and RS3 correspondingly.

Insert Figure 9 about here

These examples complete the presentation of the proposed conceptual framework for control. In the next section we will refer to its implications and potential contribution to the teaching and the learning of control-related concepts and skills.

Teaching and Learning Control

We will begin the discussion of the educational implications of the proposed framework by stressing even more (for purposes of clarity) the differentiation between the two main paradigms, programming versus design (see Figure 10).

Insert Figure 10 about here

First, as the table in Figure 10 suggests, we identified the two paradigms with their usual intellectual (and physical) habitats on university campuses: software centered (e.g., computer science) for the programming paradigm, and hardware

centered (e.g., engineering) for the design paradigm. The obvious implication here is that we are referring to different aims, concerns, methodologies, and target outcomes therefore affecting the planning of the teaching as well as the learning process.

The table in Figure 10 characterizes each paradigm according to six main issues. The first relates to the very definition of the controller. For the programmer, the controller is the device (e.g., microprocessor) in charge of performing the control program. For the designer, the controller is a collection of logical units arranged and built to perform control.

The main construct in the programming paradigm is the algorithm, or the sequence of decision points and operations involved in controlling a device. The main construct in the design paradigm is the finite-state-machine representation, focusing on the system's states and the rules of transition among them.

The two issues so far described indicate that the distinction between the two paradigms obviously affects the kind of model the person constructs while analyzing or designing the control unit of a system. We could refer to the first (the programmer's model) as a functional model, mapping mainly the sequence of steps and procedures which control the device's functioning. The designer's model could be referred to as a structural model, mapping the logical elements' configuration (and the set of their interrelations) required to govern the device's behavior.

The next issue is the way the control process is perceived within each paradigm, thus defining its respective instructional focus. Within the programming paradigm control is viewed as the process by which the control algorithm is performed. In correspondence, learning how to create the control module of the system means learning how to create the most "efficiently performable" algorithm. The design

paradigm views control as the process of transforming inputs into outputs. Learning to create a control module means learning how to create a device that is able to receive the different input values and to generate the desired outputs.

In the programming paradigm the main learning activities focus on programming knowledge and skills, seeking the creation of control programs as the main learning outcome. In the design paradigm, in contrast, the focus is on design knowledge and skills, with the main learning outcome being logical circuits or schemes.

Finally, the methodology guiding instruction in the programming paradigm involves what is known as software engineering methods, while in the design paradigm the instruction focuses on methods related to automaton synthesis or design.

The last three issues affect the nature of the knowledge base underlying the instructional process. For the programming paradigm, key knowledge includes mastery of the programming environment and language, and control-related programming techniques. For the design paradigm, key knowledge and skills include the mastery of alternative representations of the logical structure and the information configuration of the controller (e.g., logical gates, truth tables, state space diagrams), as well as of the synthesis or design process itself.

Implications for a Research and Development Agenda

In the introduction of the paper we presented a series of key (cognitive, instructional) issues regarding the teaching and learning of control concepts. The foregoing description of the two-paradigm framework and its educational implications will serve us now to reformulate these key issues in more specific terms,

for guiding further research and development efforts. Let us briefly refer to these issues.

Mental models. The different paradigms (and constructs within each paradigm) imply different mental models of the controlled system. Among the questions yet to be answered are: To what extent are these models intuitive? To what extent are they perceived as equivalent and interchangeable representations of control? How is their learning affected by individual cognitive characteristics (e.g., those related to age level, cognitive style)? How is their learning affected by previous knowledge and the existence (or absence) of prerequisite schemes? How do conceptions, missing conceptions and misconceptions of controlled systems affect the construction and application of these models?

These general questions should lead to the formulation of specific research questions. For example, a key distinction between the two paradigms resides in the way the control process is related to time. From the programming perspective control is a sequential process, where the sequence of conditional vertices (control algorithm or procedure) are activated step by step. From the design or structural paradigm the reception of whole vector X and the transition from one state to another is a simultaneous or parallel type of transformation. All the input information is checked at once, and the corresponding output (and therefore a new state) is generated. Students' conceptions (and misconceptions) of sequential versus simultaneous control processes is a central issue yet to be studied.

Teaching. The different paradigms and constructs imply differences in the knowledge base to be taught. These differences relate to varied skill sets, symbol

systems, and knowledge units (e.g., programming commands, logic gates, information paths).

Among the questions to be answered at the teaching level are: Are all the constructs equally “teachable”? What sequences for their teaching should be developed? What does it require to teach a student to gradually master the different constructs, and to be able to move from one construct to another if so required (e.g., because of the nature of the problem to be solved)? What are recommended guidelines for the design of appropriate learning environments and teaching strategies for control concepts?

Target population. A key factor affecting the matching between the content, teaching strategies, and the student, is obviously the nature of the target population. We should look for answers, both at the cognitive and the instructional level, for different student groups: School-age children learning control as part of their technological literacy studies; technology education students acquiring professional preparation; technicians getting their training for very practical and functional purposes; undergraduate and graduate students in control-related fields.

Of special interest are the issues regarding the teaching of control concepts as part of people’s technological literacy [19] -[9]. Focussing on literacy imposes guidelines as well as constraints to the definition of the teaching environment and process.

A Proposal for a Learning Environment:
The Controlled Systems Laboratory (CSL)

Aiming at building an appropriate environment for the study of the above mentioned research questions we are currently engaged in the development of a learning environment for controlled systems concepts, the Controlled Systems Laboratory (CSL). In developing the CSL we try to embody the ideas and approaches of our conceptual framework, also integrating experience accumulated in previous work. Examples of significant work that has already been done both at the hardware and software levels are the Lego-Logo system, Stella [20], Turing's World [21], as well as computerized working environments in non-educational settings (e.g., industry, agriculture). Our effort is directed to create an integrative educational working environment based on the multiple constructs framework, for studying the curricular and cognitive issues mentioned in the previous sections.

The CSL is a hardware/software/printed-materials environment. The hardware component consists of a building kit for the design of controlled devices (e.g., Lego technic, Fisher technic), and interface components (ports box, card, wiring) required to establish the computer input and output linkage to the physical devices.

A key issue in the project is the creation of the software component. The software represents the actual environment in which the student works to create control for the physical devices. Its development follows three key ideas in our conceptual framework. The first is that the software should support the different stages of the process in which control is defined, namely, the initial description, the formal-model and the implementation stages. The second is that it should offer the possibility to work with the different approaches contained in the multiple-construct framework, i.e., that the software should enable to build control, for example, by either creating a flowchart or a states-diagram. The third issue is that the software

should stress the idea that the different constructs are equivalent representations, by clearly showing that the running of the different control representations lead to a similar behavior of the physical system. At this stage we have completed the first working version of the environment, embodying two constructs, flowchart and state-diagram.

Figure 11 shows the main screen of the CSL working environment.

Insert Figure 11 about here

The printed materials component of the learning environment represent the didactic sequence of activities for learning control within the CSL system. The unit currently under development gradually presents the different control-related concepts and skills: from basic concepts, through the particular features of the different constructs, to projects (involving both construction of a device and implementing its control) of varied degrees of complexity.

As mentioned, our main purpose in formulating the conceptual framework presented in this paper and in developing the CSL learning environment, is to contribute to enrich the existent knowledge about the teaching and learning processes of control concepts and skills.

Bibliography

- [1] Simon, H. A. (1981). The sciences of the artificial. Cambridge, MA: MIT Press.
- [2] Parsegian, V. L. (1972). This cybernetic world of men machines and earth systems. Garden City, NY: Doubleday & Co.
- [3] Whalley P. (1992). Making control technology work in classroom. British Journal of Educational Tehnology, 23(3), 112-221.
- [4] Chen D.&Stroup W. (1992). Learning system thinking. Cambridge: Tufts University, H. Dudley Wright Center.
- [5] DeLuca V.William (1988). Intelligent technologies - A new basis for technology Education. Technology teacher, April, 7-10.
- [6] Resnick, M. (1991). Overcoming the centralized mindset: Towards an understanding of emergent phenomena. In I. Harel & S. Papert (Eds.), Constructionism. Norwood, NJ: Ablex Publishing Corporation.
- [7] Granott, N. (1991). Puzzled minds and weird creatures: Phases in the spontaneous process of knowledge construction. In I. Harel & S. Papert (Eds.), Constructionism. Norwood, NJ: Ablex Publishing Corporation.
- [8] Ackerman, E. (1991). The agency model of transactions: Towards an understanding of children's theory of control. In J. Montangero & A. Tryphon (Eds.), Psychologie Génétique et Sciences Cognitives. Geneva: Fondation Archives Jean Piaget.
- [9] Mioduser, D., Venezky, R. L., & Gong, B. (in press). Student models of simple control systems.
- [10] Wiener N. (1987). Cybernetics. Cambridge, MA: M.I.T.Press.

- [11] Resnick M. & Ocko S. (1991) LEGO/LOGO: Learning through and about design. In I. Harel & S. Papert (Eds.), Constructionism. Norwood, NJ: Ablex Publishing Corporation.
- [12] Bourgoin M. (1990). Children using LEGO robots to explore dynamics. In I. Harel (Ed.), Constructionist Learning, Cambridge, MA: MIT Media Laboratory.
- [13] Brown F. & Distler R. (1991). An improved state diagram. IEEE Transactions on Education, 34(2), 199-203.
- [14] McAllister, D. W. & Brock F. (1990). Using the logic diagram in teaching programming: An overview and preliminary test results. Journal of Research on Computing in Education, Spring, 348-359.
- [15] Falcione A. & Krogh H (1993). Design recovery for relay ladder logic. IEEE Control Systems, April, 90-98.
- [16] Fiedler C. & Alford C. (1992). Easy state tables for compound statement sequence detectors. IEEE Transactions on Education, 35(3), 243-246.
- [17] Abelson, H., Sussman, G. J., & Sussman, J. (1985). Structure and interpretation of computer programs. Cambridge, MA: MIT Press.
- [18] Sandige, R. S. (1990). Modern digital design. NY: McGraw-Hill.
- [19] Johnson, J. R. (1989). Technology - report of the project 2061 phase I technology panel. American Association for the Advancement of Science.
- [20] Richmond B., Peterson S. & Vescuso P. (1987). An academic user's guide to STELLA. Lyme, NH: High Performance Systems, Inc.
- [21] Barwise J. & Etchemendy J (1986). Turing's World. Santa Barbara, CA: Kink'o Academic Courseware Exchange.

Figure Captions

- Figure 1. Schematic structure of a controlled system.
- Figure 2. The “line-seeker” device.
- Figure 3. Multiple-constructs framework.
- Figure 4. Flowchart for the “line-seeker” device.
- Figure 5. D-functional description for the “line-seeker” device.
- Figure 6. State-diagram for the “line-seeker” device.
- Figure 7. Canonical structure of the control unit.
- Figure 8. Logical gates scheme for the “line-seeker” device.
- Figure 9. Ladder diagram description for the “line-seeker” device.
- Figure 10. Comparison between the programming and design control paradigms.
- Figure 11. Main screen of the Controlled Systems Laboratory (CSL) learning environment.

Figure 1. Schematic structure of a controlled system.

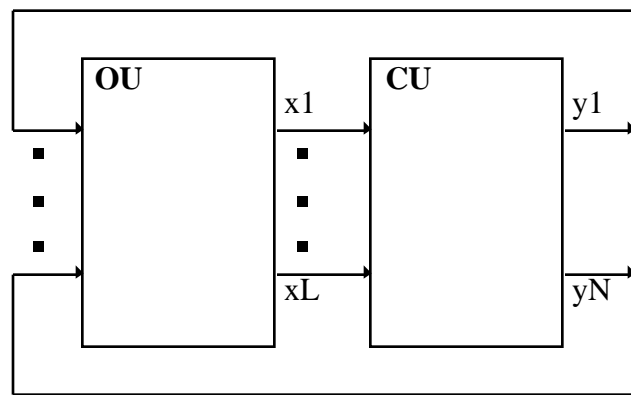

Figure 2. The “line-seeker” device.

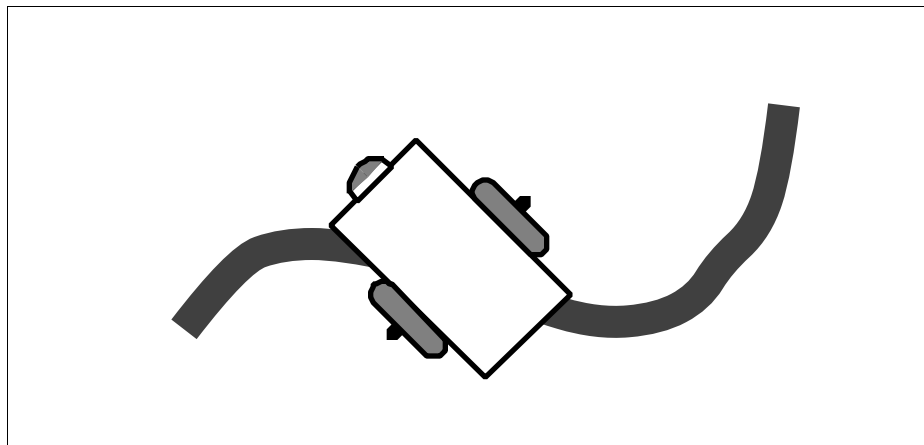

Figure 3. Multiple-constructs framework.

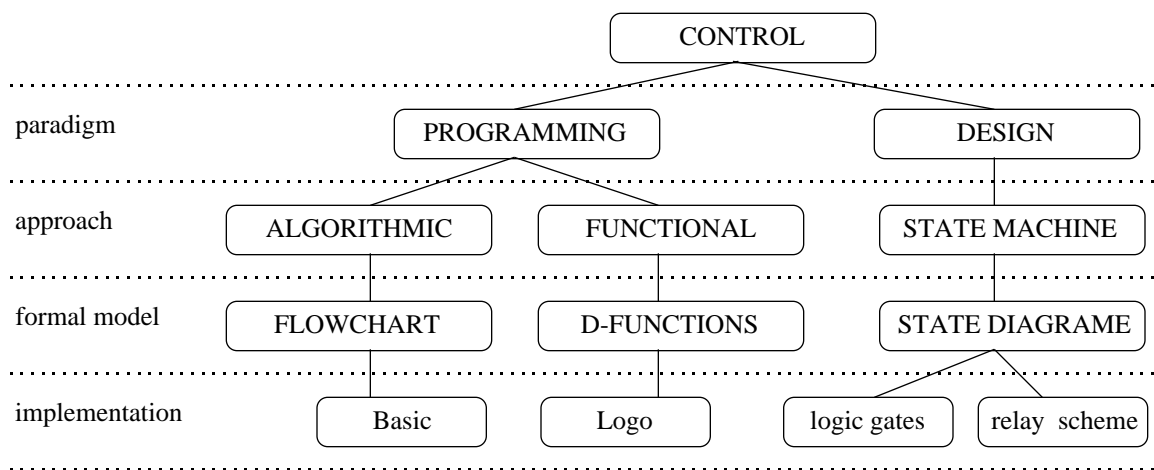

Figure 4. Flowchart for the “line-seeker” device.

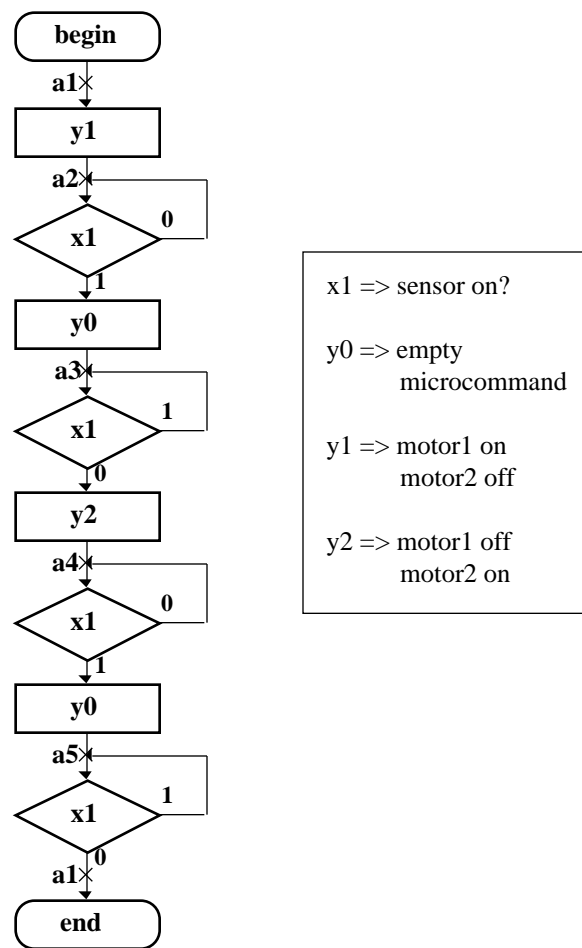
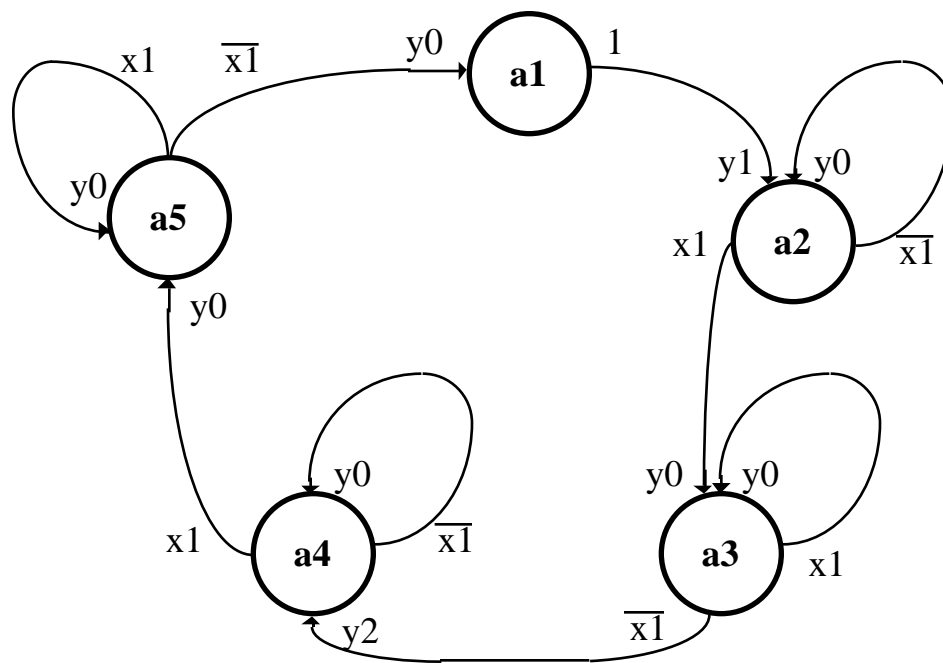

Figure 5. D-functional description for the “line-seeker” device.

Formal D-functional description of control	
<p>D1 ==> Y1#D2#Y2#D2#Y3#D1;</p> <p>D2 ==> D21#Y0#D22;</p> <p>D21 ==> X1Y0+X1'D21;</p> <p>D22 ==> X1D22+X1'Y0.</p>	<p>where: Y0 - empty microinstruction Y1 - motor 1 on Y2 - motor 1 off, motor 2 on Y3 - motor 2 off D2 - turning until two changes of color D21 - turning until first change of color D22 - turning until second change of color</p>
LOGO representation of D-functional description:	
<p>TO D1 Y1 D2 Y2 D2 Y3 D1 END</p> <p>TO D2 D21 Y0 D22 END</p> <p>TO D21 WAITUNTIL [X1] D21 END</p> <p>TO D22 WAITUNTIL [NOT X1] D22 END</p>	<p>TO Y1 TTO 0 ON END</p> <p>TO Y2 TTO 0 OFF TTO 1 ON END</p> <p>TO Y3 TTO 1 OFF END</p>

Figure 6. State-diagram for the “line-seeker” device.



Transition table
 $a(t+1)=\delta(a(t),x(t))$

$x \backslash a$	a_1	a_2	a_3	a_4	a_5
0	a_2	a_3	a_4	a_4	a_1
1	a_2	a_2	a_3	a_5	a_5

Output table
 $y(t)=\lambda(a(t),x(t))$

$x \backslash a$	a_1	a_2	a_3	a_4	a_5
0	y_1	y_0	y_2	y_0	y_0
1	y_1	y_0	y_0	y_0	y_0

Figure 7. Canonical structure of the control unit or sequential machine

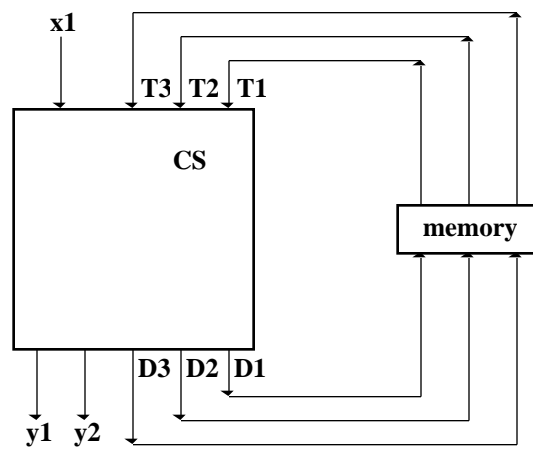

Figure 8. EPROM Implementation for the “line-seeker” device.

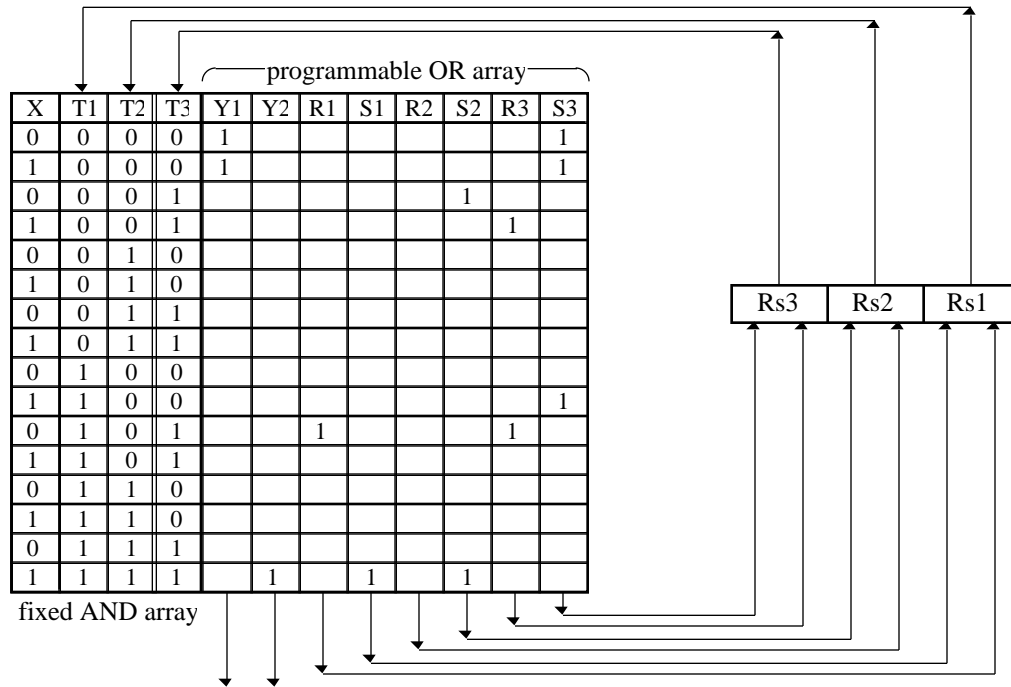

Figure 9. Ladder diagram description for the “line-seeker” device.

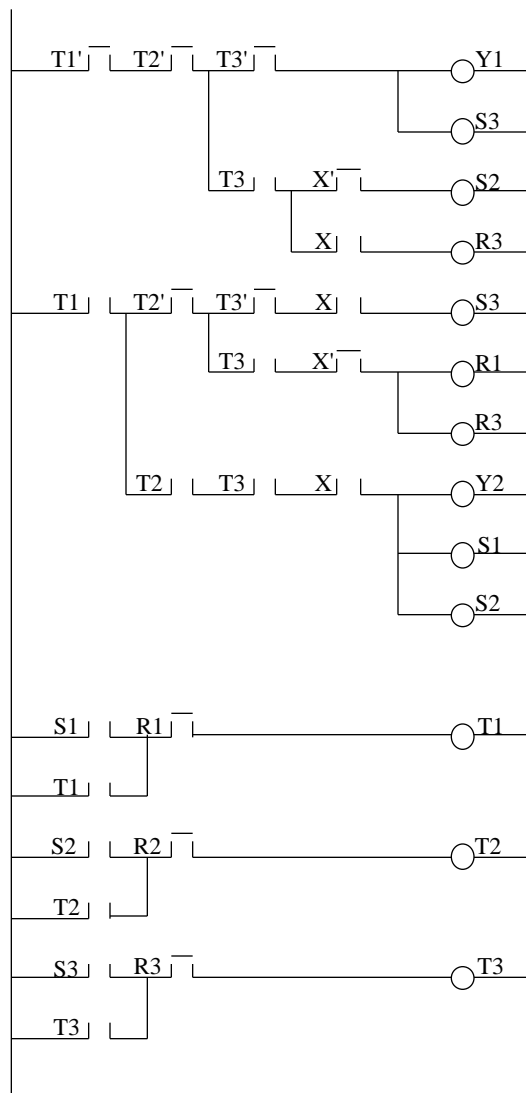

Figure 10. Comparison between the programming and design control paradigms.

	programming paradigm (software-centered)	design paradigm (hardware-centered)
Controller defined	device for performing the control program	collection of logical units embodying control
main construct	algorithm	state machine
control process	implementation of the control algorithm	input/output transformations
learning activity	programming	design
learning outcome	program	logical circuit or scheme
methodology	software engineering methods	automaton synthesis methods

Figure 11. Main screen of the Controlled Systems Laboratory (CSL) learning environment.

